

P/N: MANUALXCU

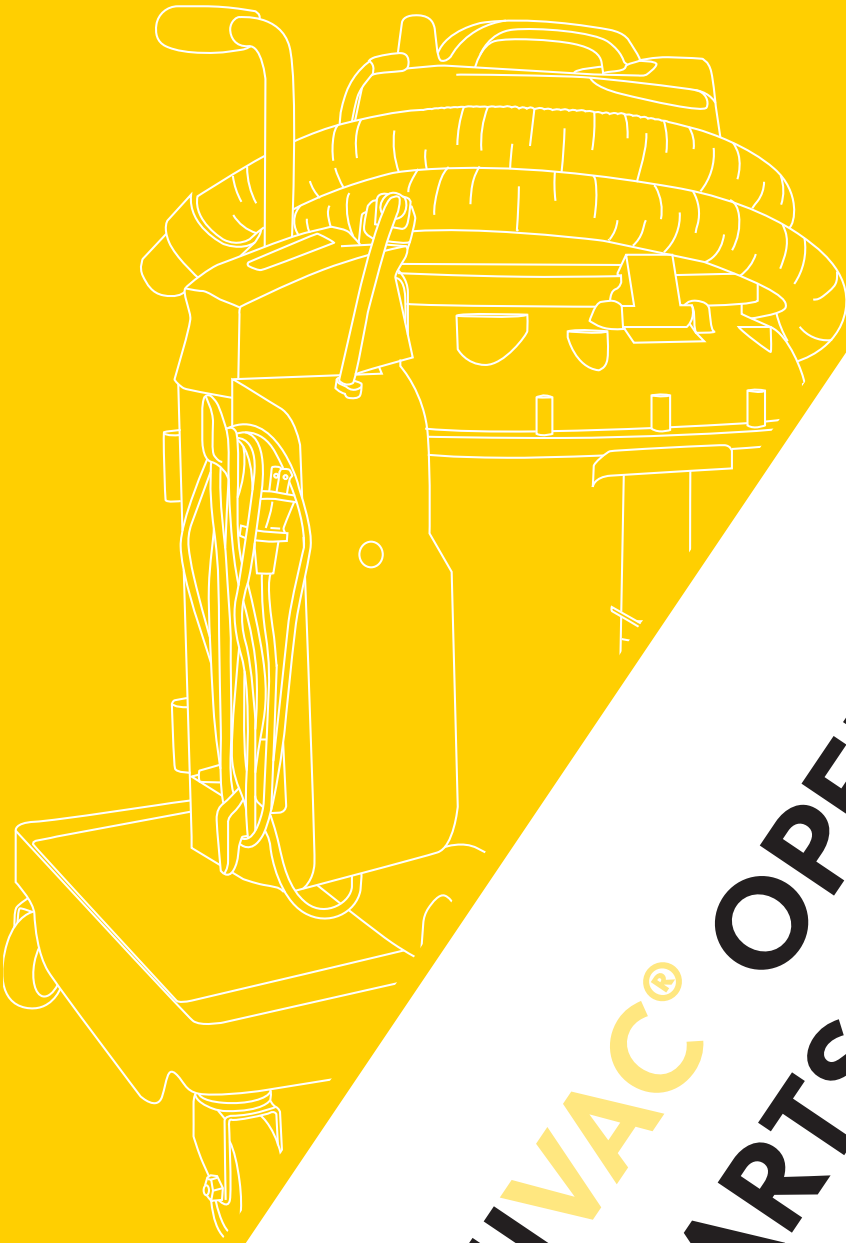

# UNIVAC<sup>®</sup> OPERATOR & PARTS MANUAL



**KAIVAC<sup>®</sup>**

[www.kaivac.com](http://www.kaivac.com)

# REVISION SHEET FOR MANUALXCU

Release No.	Date	Revision Description
1	03/11/20	Initial design/release of MANUALXCU
2	06/18/20	Edit to 4.1, 4.2 and 4.3
3	06/22/21	Update to branding of MANUALXCU
4	07/15/21	Battery Warning Update
5	01/25/2022	Battery Information Update
6	01/18/24	Manual Update, Battery Information, Part Numbers, Images
7	01/13/25	Manual Update, Battery Information, Images

NOTE: Specifications and parts are subject to change without notice

## **Kaivac, Inc.**

2680 Van Hook Ave.

Hamilton, OH 45015

Customer/Technical Support

1-800-287-1136



**Do not attempt to operate the machine before reading and understanding this manual. Pay close attention to all WARNINGS, CAUTIONS and NOTES. Failure to do so may cause serious injury and extensive machine damage**

---

# OPERATOR & PARTS MANUAL - TABLE OF CONTENTS

---

## **1.0 Getting Started**

1.1 PRODUCT IDENTIFICATION .....	4
1.2 WARRANTY REGISTRATION .....	4
1.3 LIMITED WARRANTY PROTECTION PLAN .....	5
1.4 IMPORTANT SAFETY INSTRUCTIONS .....	6
1.4 IMPORTANT SAFETY INSTRUCTIONS (CONTINUED) .....	7
1.4 IMPORTANT SAFETY INSTRUCTIONS (CONTINUED) .....	8
1.5 BATTERY INFORMATION.....	9
1.6 HELMET ADDENDUM.....	10
1.7 GROUNDING INFORMATION.....	11
1.7 GROUNDING INFORMATION (CONTINUED) .....	12

## **2.0 Operation**

2.1 BATTERY HOUSING AND CHARGING.....	13
2.2 TOOL ARRANGEMENT.....	14
2.3 PREPARATION FOR USE.....	15
2.3 PREPARATION FOR USE (CONTINUED).....	16
2.4 FILLING THE UNIT.....	17
2.5 EMPTYING VACUUM TANK.....	17
2.6 UniVac® OPERATION .....	18

## **3.0 Maintenance**

3.1 MACHINE & BATTERY MAINTENANCE.....	19
3.2 DC BATTERY QC POWER PACK ELECTRICAL DIAGRAM.....	20
3.3 AC CORDED ELECTRICAL DIAGRAM.....	21

## **4.0 Troubleshooting**

4.1 TROUBLESHOOTING TIPS .....	22
4.2 REPLACEMENT (MONTHLY) .....	22
4.3 TROUBLESHOOTING.....	23
4.3 TROUBLESHOOTING (CONTINUED).....	24
4.3 TROUBLESHOOTING (CONTINUED).....	25

## **5.0 Parts Diagrams and Specification**

5.1 VACUUM TANK ASSEMBLY PARTS DIAGRAM .....	26
5.2 VACUUM HEAD ASSEMBLY PARTS DIAGRAM .....	27
5.3 QUICK CHANGE POWER PACK (BATTERY) ASSEMBLY PARTS DIAGRAM .....	27

---

## 1.1 PRODUCT IDENTIFICATION

### UNIVAC® (CORDED)

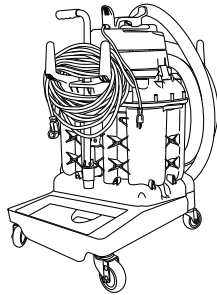

### UNIVAC® (BATTERY)

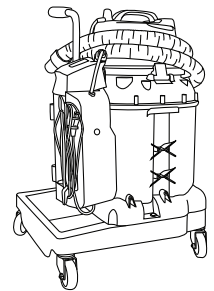

---

## 1.2 WARRANTY REGISTRATION

Thank you for purchasing a Kaivac unit. Please take a few moments to register your unit at [kaivac.com/warranty](http://kaivac.com/warranty).

Why register?

- Ensure your warranty coverage
- Simplify warranty service in the future with your information on file
- Be the first to know about upgrades, issues, new options and special offers.

## 1.3 LIMITED WARRANTY PROTECTION PLAN

5 YEAR TROLLEY/TANK AND 1 YEAR PARTS AND LABOR (EXCLUDING BATTERY) Kaivac warrants to the original purchaser/user that the vacuum tank and bucket body are free from defects in workmanship and materials under normal use for a period of Five Years, and the battery interface and components (excluding Lithium-ion battery), vacuum motor, and spray system are free from defects in workmanship and materials under normal use for a period of One Year. This warranty does not include accessories or wear items. Items EXCLUDED from coverage: Squeegee blades and wheels, hoses, seals, gaskets, cords, casters, HEPA filter cartridges, chemical feed caps, spray gun, GFCI, vacuum wand assembly and other accessory tools.

- *Please Note:* using inappropriate chemicals constitutes misuse of these machines. These machines are not meant to be used with high-foaming or corrosive chemicals. Please check with your distributor or with Kaivac if you have questions about your chemical.

### Battery Program Details

- Battery Warranty covers 2 years on a defective Battery.
- Battery Warranty covers the replacement of the Battery unit.
- Battery replacement remains under Warranty only for the remaining Warranty period of the original Battery unit (for a maximum of 2 years from the date of purchase of the unit).

### WARRANTY LIMITATIONS:

- This warranty does not assume responsibility for damage or faulty performance caused by misuse or abuse, or where repairs or modifications have been made or attempted. Kaivac will make the final determination on whether the damage falls under this limited warranty for manufacturer's defects.
- The following actions constitute misuse or neglect of the battery that void the warranty of the battery:
  - Any modifications to the unit may nullify any warranty
  - Improper installation of the Quick Change battery
  - Exposure of the battery to temperatures above and below the battery limits
  - Use of any charger besides the supplied Kaivac® charger
  - Dropping the battery box
  - Long term storage of the battery without maintaining a battery charge of 25 to 40% capacity
  - Removal of the vacuum motor cord strain relief will void warranty. Do not remove the strain relief.
- **UNDER NO CIRCUMSTANCES WILL KAIVAC BE LIABLE FOR ANY LOSS, DAMAGE, EXPENSES OR CONSEQUENTIAL DAMAGES ARISING IN CONNECTION WITH THE USE OR INABILITY TO USE THE KAIVAC UNIT. THIS WARRANTY IS IN LIEU OF ANY OTHER WARRANTY EXPRESSED OR IMPLIED, INCLUDING ANY WARRANTY OF MERCHANTABILITY OR FITNESS FOR A PARTICULAR PURPOSE.**

# 1.4 IMPORTANT SAFETY INSTRUCTIONS

**SAVE THESE INSTRUCTIONS**  
**CONSULT KAIVAC.COM FOR THE MOST UP TO DATE SAFETY PRECAUTIONS**  
**READ ALL INSTRUCTIONS BEFORE USING (THIS UNIT)**  
**IMPROPER USE OF UNIT CAN RESULT IN SERIOUS INJURY.**

When using an electrical unit, basic precautions should always be followed, including the following:



**To reduce the risk of fire, electric shock, or injury:**

## GENERAL SAFETY INSTRUCTIONS (APPLICABLE TO CORDED AND BATTERY UNITS):

- For commercial use only.
- DO NOT allow unit to be used as a toy and unit should not be operated by children. Close attention is necessary when used near children.
- Use unit only as described in this Manual. Use only Kaivac's recommended attachments.
- DO NOT put any object into unit's openings. Do not use with any of the unit's opening blocked; keep free of dust, lint, hair, and anything that may reduce air flow.
- Keep hair, loose clothing, fingers, and all parts of body away from openings and moving parts.
- Use extra care when cleaning on stairs.
- NO COMBUSTIBLES! Sparks inside the motor can ignite flammable vapors or dust. Do not use unit near combustible liquids and gases, or to pick up explosive dusts or gasoline.
- CHECK FLOAT on Vacuum Motor and clean before each use. Clogged screen may lead to loss of suction.
- DO NOT pick up anything that is burning or smoking, such as cigarettes, matches or hot ashes.
- To reduce the risk of injury, close supervision is necessary when a unit is used near children.
- Stay alert - watch what you are doing.
- Keep operating area clear of all persons.
- DO NOT overreach or stand on unstable support. Keep good footing and balance at all times.
- DO NOT operate without the Vacuum Motor Float Cage installed. If float is removed, reinstall by screwing back into place.
- DO NOT use without filters in place.
- DO NOT operate the unit when fatigued or under the influence of alcohol or drugs.
- Know how to stop the unit and bleed pressures quickly. Be thoroughly familiar with the unit's controls before operating.
- Follow the maintenance instructions specified in this Manual.

## SPRAY SYSTEM SAFETY INSTRUCTIONS (APPLICABLE TO CORDED AND BATTERY UNITS):

- DO NOT spray liquid from the unit or attachments onto electrical outlets or any electrical devices.
- Risk of injection or injury to persons - DO NOT direct discharge stream at persons.
- INJECTION HAZARD: Unit can cause serious injury if the spray permeates the skin. Do not point the spray gun at anyone or any part of the body. In case of permeation, seek medical aid immediately.
- THIS UNIT IS CAPABLE OF PRODUCING 500 PSI (3447 kPa). To avoid rupture and injury, do not operate this pump with components rated less than 500 PSI (3447 kPa) working pressure (including but not limited to spray guns, hose, and hose connections); and before servicing, cleaning or removal of any part, shut off power and relieve pressure.
- High pressure cleaners, such as this unit, shall not be used by children, persons with reduced physical, sensory or mental capabilities or lack of experience and knowledge or untrained personnel. Children should not play with the unit. Cleaning and user maintenance should not be performed by children.
- This unit may also have been provided with a ground fault circuit interrupter built into the power cord. If replacement of the plug or cord is needed, use only identical replacement parts.
- Test the unit's ground fault circuit interrupter (GFCI) before each use.
- **Personal Protective Equipment (PPE): It is recommended to wear proper personal protective equipment as required by the chemical product label instructions used in conjunction with the unit. For Kaivac chemical products, refer to product label.**

## CORDED UNITS SAFETY INSTRUCTIONS (APPLICABLE TO CORDED UNITS):

- Connect to a properly grounded outlet only. Do not remove ground pin on plug. See Grounding Instructions below.
- Inspect cord prior to use. Do not use with damaged cord or plug. If unit is not working as it should, has been dropped, damaged, left outdoors or dropped into water, do not use or charge and return unit to a Kaivac service center.
- Turn off the unit before unplugging. Do not leave unit when plugged in. Unplug from outlet when not in use and before servicing.
- DO NOT handle plug or unit with wet hands.
- DO NOT pull or carry by cord, use cord as handle, close a door on cord, or pull cord around sharp edges or corners. Do not run unit over cord. Keep cord away from heated surfaces.
- DO NOT unplug by pulling on cord. To unplug, grasp the plug, not the cord.
- Turn off all controls before unplugging.
- If using extension cord with unit, make sure the connection is above and off the floor and away from exposure to liquid.
- Keep all connections dry and off the ground.
- The unit must be disconnected from any electrical or battery source when the unit is being cleaned or maintenance of unit or when replacing parts.
- Keep the cord away from heated surfaces.
- This unit comes with a grounded attachable extension cord. If cord is damaged, replace with equivalent 120v, 15amps, 14GA rated cord. This cord must be attached and mechanically secured using the provided cord connector to use the unit.

FOR INDOOR USE ONLY  
 INTENDED FOR COMMERCIAL USE

**WARNING** To Reduce the Risk of Electric Shock — Do not expose to any liquids Store indoors.

# 1.4 IMPORTANT SAFETY INSTRUCTIONS (CONTINUED)

SAVE THESE INSTRUCTIONS  
CONSULT [KAIVAC.COM](http://KAIVAC.COM) FOR THE MOST UP TO DATE SAFETY PRECAUTIONS  
READ ALL INSTRUCTIONS BEFORE USING (THIS APPLIANCE)  
IMPROPER USE OF PRODUCT CAN RESULT IN SERIOUS INJURY.

When using an electrical unit, basic precautions should always be followed, including the following:



**To reduce the risk of fire, electric shock, or injury:**

## BATTERY UNITS SAFETY INSTRUCTIONS (APPLICABLE TO BATTERY UNITS):

- ONLY USE with Kaivac, Inc. battery, and charger, CHARG36V series.
- Use unit only with specifically designated battery. Use of any other battery may create a risk of personal injury, property damage including risk of explosion, or fire.
- When charging battery, make sure charger or unit has at least 6 inches of clearance on all sides for adequate air flow.
- The battery splash cover must remain in place. Without the battery splash cover, the battery housing may become damaged which may cause the battery to malfunction, which can result in a fire, explosion, personal injury, and/or property damage.
- **Never use a battery that has been damaged in any way.** Damaged batteries may exhibit unpredictable behavior resulting in fire, explosion, or risk of personal injury and property damage. **Never use or charge a damaged battery pack.**
- **Never dispose of the battery in the trash. It is important that your old, damaged battery is disposed of and/or returned as instructed by Kaivac Customer Care/Technical Support at 1-800-287-1136.**
- DO NOT allow battery to be submerged in water.
- DO NOT use a battery that has been submerged in water, or if water has infiltrated the battery housing even if it appears to be working, as fire or explosion may result.
- DO NOT charge batteries outdoors.
- DO NOT attempt to repair, service or modify the batteries or charger. Contact Kaivac Technical Support with any issues.
- DO NOT short-circuit the battery or charger terminals with conductive items such as paper clips. This can deliver high current, resulting in heat and fire.
- Keep heat sources, sparks, and flames away from batteries.
- DO NOT crush, drop, incinerate or damage the battery.
- DO NOT use a battery that has been damaged in any way. DO NOT incinerate the battery even if it is non-working or severely damaged. The battery can explode in a fire.
- DO NOT expose a battery or unit to fire or excessive temperature. Exposure to fire or temperature above 265°F (130°C) may cause explosion resulting in fire, property damage, and personal injury.
- DO NOT use or store the NTC System or battery in refrigerated areas, in environments when the battery is in direct contact with liquids, or near flammable or combustible materials.
- DO NOT charge or store battery for extended time (1 month or more) in temperatures below 40°F (4°C).
- If battery emits fumes, smoke, sparks, or fire, discontinue use immediately. Do not touch battery. If unit can be safely moved, move to well ventilated area away from people or combustible material.
- Prevent unintentional starting. Ensure the switch is in the off-position before connecting to battery, picking up or carrying the unit. Do not carry the unit with your finger on the switch. Energizing an unit that has the switch on invites accidents.
- DO NOT remove any part of the battery, charging unit, or unit: If your unit has a chemical-resistant plastic protective helmet, do not remove it.
- If you unit contains a chemical-resistant plastic protective helmet, consult the Helmet Addendum for additional instructions and warnings.
- Exposure of units to airborne polyunsaturated fats in the food service industry may cause deterioration of battery components. Failure to inspect and use as instructed may result in fire explosion, personal injury, or property damage.
- Stop use immediately if the battery or unit sparks or shows signs of fire.
- DO NOT leave battery connected to charger once the charger light is green. Leaving battery on charger will diminish the life of the battery and may result in fire.
- Inspect the battery before each use for damage, dents, cracks, or holes.
- Disconnect the battery from the unit before making any adjustments, changing accessories, or storing unit. Such preventive safety measures reduce the risk of starting the unit accidentally.
- When battery is not in use, keep it away from other metal objects like paper clips, coins, keys, nails, screws or other small metal objects that can make a connection from one terminal to another. Connecting or shorting the battery terminals together may cause burns or a fire.
- Under certain conditions, including damage or liquid infiltrating the battery's interior cells, the battery may emit smoke, sparks, or fire. Liquid may be ejected from the battery; avoid contact. If contact accidentally occurs, flush with water. If liquid contacts eyes, additionally seek medical help. Liquid ejected from the battery may cause irritation or burns.
- DO NOT use a battery or unit that is damaged or modified. Damaged or modified batteries may exhibit unpredictable behavior resulting in fire, explosion or risk of injury.
- If unit is smoking or sparking, and unit can be safely moved, move unit outside to a fire-safe location immediately. Contact emergency services and call Kaivac Technical Support at 800-287-1136, Ext. 2.
- DO NOT plug battery in while Vacuum Motor is in ON position. It may damage the system.

FOR INDOOR USE ONLY  
INTENDED FOR COMMERCIAL USE

**WARNING** To Reduce the Risk of Electric Shock — Do not expose to any liquids Store indoors.

## 1.4 IMPORTANT SAFETY INSTRUCTIONS (CONTINUED)

SAVE THESE INSTRUCTIONS  
CONSULT [KAIVAC.COM](http://KAIVAC.COM) FOR THE MOST UP TO DATE SAFETY PRECAUTIONS  
READ ALL INSTRUCTIONS BEFORE USING (THIS UNIT)  
IMPROPER USE OF UNIT CAN RESULT IN SERIOUS INJURY.

When using an electrical unit, basic precautions should always be followed, including the following:



**To reduce the risk of fire, electric shock, or injury:**

### CHARGER/ELECTRICAL WARNINGS:

- Connect charging cord to a properly grounded outlet only. See Grounding Instructions.
- DO NOT plug in charger while Vacuum Head is in ON position. It may damage the unit's electrical system.
- Follow all charging instructions and do not charge the battery or unit outside of the temperature range specified in the instructions. Charging improperly or at temperatures outside of the specified range may damage the battery and increase the risk of fire.
- DO NOT leave charger plugged in when not in use.
- DO NOT operate charger if it has received a sharp blow, been dropped, or damaged in any way.
- DO NOT use charger if it has a damaged cord or plug. DO NOT carry charger by cord.
- DO NOT pull on charger cord to unplug. Grasp and pull the plug, not the cord.
- DO NOT handle charger, including charger plug and charger terminals, with wet hands while charger is plugged in or while inserting plug into electrical outlet.

## QUICK RELEASE INSTRUCTIONS

**These instructions only apply to legacy units containing the metal plug connector.**

1. To disconnect the vacuum motor from the battery housing, push the button on the electrical connector and pull toward you to disengage the motor electrical cord from the battery housing.
2. Then to remove the battery from the unit, while standing at the rear of the unit, grab the battery by the handle and lift it up away from the unit.
3. To reconnect the battery housing to the vacuum motor, insert the motor electrical connector into the Battery Pack outlet, aligning the key features of the electrical connector into the outlet key-way. Press the connector into the outlet until it clicks to lock into place.

**Personal Protective Equipment (PPE):** It is recommended to wear proper personal protective equipment as required by your chemical product label instructions used in conjunction with the unit. For Kaivac chemical products refer to the label.



**WARNING** To Reduce the Risk of Electric Shock — Do not expose unit or battery to any liquids. Store indoors.



To recycle battery, call Kaivac Customer Care at 1-800-287-1136 to order a recycling box. Disposal of batteries are regulated by federal law and must be done properly.

## 1.5 BATTERY INFORMATION

**Keep Batteries at Room Temperature:** Store between 32 and 113 degrees F (0°C to 45°C). Avoid battery exposure to extreme temperatures. If shelving battery longer than (1) month, deplete battery to 50% charge during storage period (two bars on the battery indicator).

**Batteries Lose Capacity Over Time:** Batteries naturally deteriorate over time whether being used or not. If battery use instructions are properly followed, batteries deteriorate at a rate of approximately 10% run time per year but may vary by patterns of use.

**Fully Discharge vs. Partial Discharge and the Effect on Battery Cycles:** Unlike lead acid batteries typically used in an auto scrubber, the original battery is not damaged by fully discharging. The BMS (Battery Management System) has a cutoff voltage of 30V which protects the Battery from experiencing full discharge. Running the battery to full discharge will reduce the amount of charge cycles. The expected hours of use are approximately 600 hours. For example, if running to full discharge, you would expect 400 cycles. If you run to 80% discharge, then user would expect to get more cycles (500 cycles). With dual batteries make sure to alternate batteries per charge in order to maximize for full life capacity.

**Extended Storage:** It is recommended to discharge to 50% capacity (two bars on the battery indicator) and store in a cool location (between 32°F to 113°F or 0°C to 45°C). To avoid battery impact, store battery laying down on its side on lowest shelf, and secured. If battery is dropped or experiences an impact or damage, discontinue use and replace. Never use a damaged battery, as a damaged battery may act in an unpredictable manner resulting in fire, explosion, property damage, or personal injury.

**Battery Gauge:** The Kaivac provided battery comes with a built-in Battery Gauge or which shows the approximate run time for the current charge remaining.

**Replacement - End of Life:** Rechargeable batteries eventually wear out. When your Kaivac Battery run time is less than 55% (i.e. 50 minutes for non-quick change and 33 minutes for Quick Change batteries), Kaivac recommends replacing your battery. Regardless of run time, contact Kaivac to replace your battery after 4 years. Consult [kaivac.com](http://kaivac.com) for information on recycling your old battery through a licensed disposal facility.

**⚠ WARNING** DO NOT DISCARD BATTERY INTO TRASH! Doing so can lead to a fire. It is important to recycle your old batteries at your local authorized battery recycling facility or by calling [1-800-USA-CLEAN \(1-800-872-2532\)](tel:1-800-USA-CLEAN) and selecting Option 3.

Battery Specifications	
Weight	With Box, 11 lbs. (4,9 kg)
Body Material	Injection Mold Polypropylene
Dimensions (H x W x D)	18 x 7 x 5 in. (45,7 x 17,8 x 12,7 cm)
Voltage	36V DC
Battery Capacity	15 A-hr
Battery Current	15 A DC
Battery Type	Lithium-Ion
Approx. Run Time BOL (Beginning of Life)	60 minutes
Approx. Run Time EOL (End of Life)	35 minutes (discontinue use and take to recycling center)
Battery Box Receptacle	IP65 / IP67 (not required for UL)
Run Time Hour Meter	Acts as "odometer for battery" and runs only when motor switch is ON
Approx. Charge Cycles	400 @ 100% discharge / 500 @ 80% discharge
Cut off Voltage (fully discharged)	30V
Charger Specifications	
Approx. Charge Time	5 hours
Charger Amps	4 Amps
Charge Voltage	42V DC
Charger Voltage	110-240VAC / 36VDC (240VAC version only needs correct plug for wall outlet)
Charging Robustness	No special instructions
Battery Charge Memory	None
Battery Charge Gauge	Yes, LED Indicator
Approx. Charge Cycles	400 @ 100% discharge / 500 @ 80% discharge
Storage/Inventory:	
Storage & Operation Ambient Temp	32°F (0°C) to 113°F(45°C)
Storage & Shipping Charge	40-60% Charge (35-38VDC)

## 1.6 HELMET ADDENDUM

### Helmet Addendum

#### Kaivac Univac® Units with a Lithium-Ion Battery Model Nos. XCU004, XCU005, XCU006, UVWB00

Battery-charged Univac models (Model No. XCU004, XCU005, XCU006, UVWB00) have experienced incidents in certain food service environments where the battery splash cover was not in place and the plastic top of the battery experienced deterioration due to exposure of airborne poly-unsaturated fats causing the plastic top to become brittle and susceptible to cracking. Damage to the battery housing, including cracking on the top, can allow liquid to get into the battery's lithium-ion cells. This may cause the battery to malfunction, which can result in fire, explosion, personal injury, and/or property damage.

Battery-powered Univac units (Model No. XCU004, XCU005, XCU006, UVWB00), which have been used in the food service industry where airborne polyunsaturated fats have been present, should have a lithium-ion battery outfitted with a chemical-resistant plastic protective helmet. If your unit does not have the chemical-resistant plastic protective helmet, immediately inspect the lithium-ion battery of your Univac unit for any damage or cracking. To view the battery, the operator should temporarily move aside the battery/splash cover in order to visually inspect the battery housing for any type of physical damage including cracks, dents, missing pieces, or holes. **If you notice any damage, immediately stop using it and do not charge your unit.**

Contact Kaivac Technical Support at 1-800-287-1136 ext. 2 for further instructions and/or assistance in the proper disposal of battery.

Never dispose of the battery in the trash. It is important that your old, damaged battery is disposed of and/or returned to a licensed disposal facility as instructed by Kaivac Customer Care/Technical Support at 1-800-287-1136.

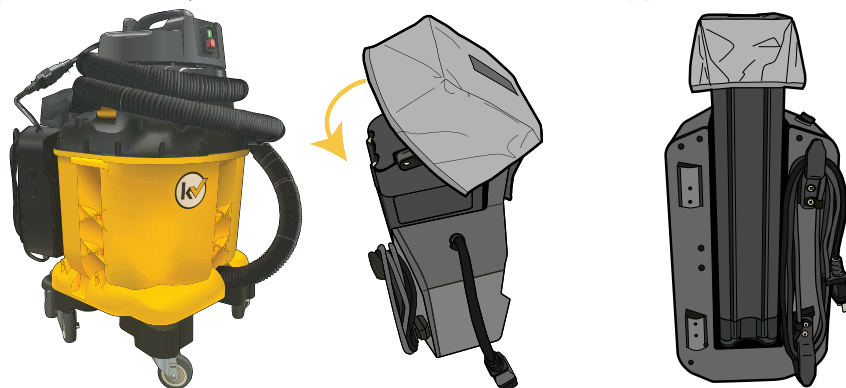

The battery splash cover protects the battery from airborne chemicals and liquids. The battery splash cover should be installed over the battery per the diagram above while the unit is being used and during charging. This will provide additional protection for the battery from exposure to airborne substances and splashes water and cleaning solutions.

All Operator & Parts Manuals can be accessed at: <https://kaivac.com/kaivac-product-manuals/>

Should you have any questions or concerns, reach out to our Kaivac Customer Care/Technical Support team at 1-800-287-1136.

## 1.7 GROUNDING INFORMATION



**WARNING**

**RISK OF ELECTRIC SHOCK OR FIRE**

### Grounding: Corded Units

#### GROUND FAULT CIRCUIT INTERRUPTER PROTECTION *(for spray systems only)*

If your unit is a corded unit, it has been supplied with a ground-fault circuit-interrupter(GFCI) built into the plug of the power-supply cord. This GFCI device provides additional protection from the risk of electric shock. Should replacement of the plug or cord become necessary, use only identical replacement parts that include GFCI protection.

If your unit is a corded unit, it is for use on a nominal circuit and has a grounding attachment plug. Make sure that the appliance is connected to an outlet having the same configuration as the plug. No adapter should be used with this unit.

#### GROUNDING INSTRUCTIONS

If your unit is a corded unit, it must be grounded. If the unit should malfunction or breakdown, grounding provides a path of least resistance for electric current to reduce the risk of electric shock. This unit is equipped with a cord having an equipment-grounding conductor and a grounding plug. The plug must be plugged into an appropriate outlet that is properly installed and grounded in accordance with all local electrical codes and ordinances.



Improper connection of the unit-grounding conductor can result in a risk of electric shock. Check with a qualified electrician or service person if you are in doubt as to whether the outlet is properly grounded. Do not modify the plug provided with the unit by removing the ground pin on the plug – if the plug will not fit the outlet, have a proper outlet installed by a qualified electrician.

This unit comes with a grounded attachable extension cord. If damaged, replace with Kaivac® (OEM) cord, or if necessary an equivalent cord rated 120V, 15 amps, 3-wire, 14 GA. This cord must be attached and mechanically secured using the provided cord connector to use the unit.

### Grounding: Battery Units

#### GROUNDING INSTRUCTIONS

The charger must be grounded. If it should malfunction or breakdown, grounding provides a path of least resistance for electric current to reduce the risk of electric shock. This unit is equipped with a cord having equipment grounding conductor and grounding plug. The plug must be inserted into an appropriate outlet that is properly installed and grounded in accordance with all local codes and ordinances.



Improper connection of the unit-grounding conductor can result in a risk of electric shock. Check with a qualified electrician or service person if you are in doubt as to whether the outlet is properly grounded. Do not modify the plug provided with the unit by removing the ground pin on the plug – if the plug will not fit the outlet, have a proper outlet installed by a qualified electrician.

This unit is for use on a nominal circuit and has a grounding attachment plug. Make sure that the unit is connected to an outlet having the same configuration as the plug. No adapter should be used with this unit.

## 1.7 GROUNDING INFORMATION (CONTINUED)

Make sure your extension cord is in good condition and is the correct size for your unit. Table 1 shows the correct size to use depending on cord length and nameplate ampere rating. If in doubt, use the next heavier gauge. The smaller the gage number, the heavier the cord. An undersized extension cord will cause a drop in line voltage resulting in loss of power and overheating.

Use only three-wire outdoor extension cords that have three-prong grounding receptacles that accept the unit’s plug.

**WARNING** To reduce the risk of personal injury due to a loose electrical connection between the unit’s plug and extension cord, firmly and fully attach the unit plug to the extension cord. Periodically check the connection while operating the unit to ensure it is fully attached. Do not use an extension cord that provides a loose connection. A loose connection may result in overheating, fire, and increases the risk of a burning.

To reduce the risk of disconnection of the unit’s cord from the extension cord during operations:

- Make a knot as shown in Figure 1 below:

**Figure 1** - Method of securing the appliance cord to the extension cord set

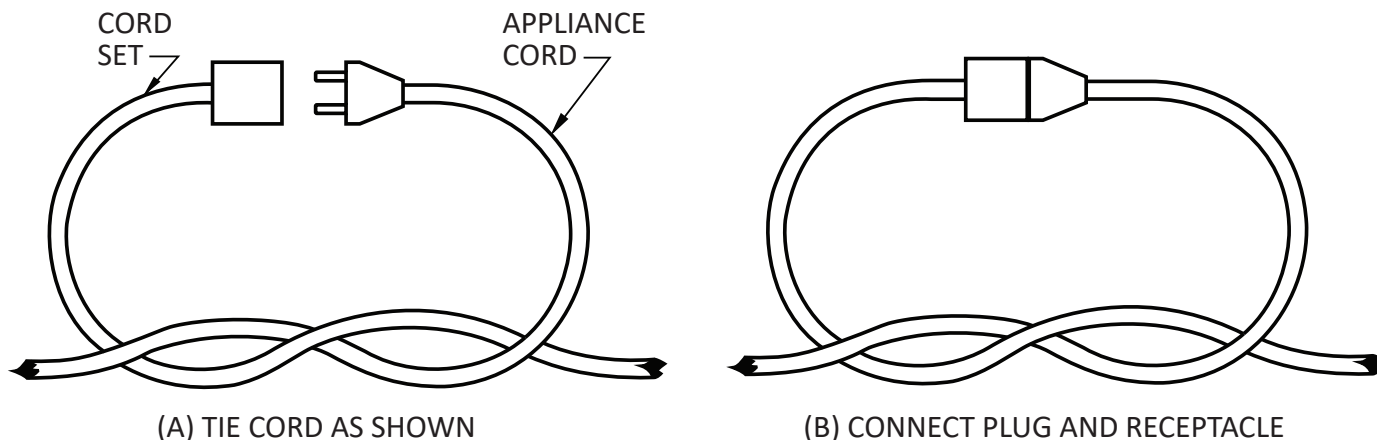
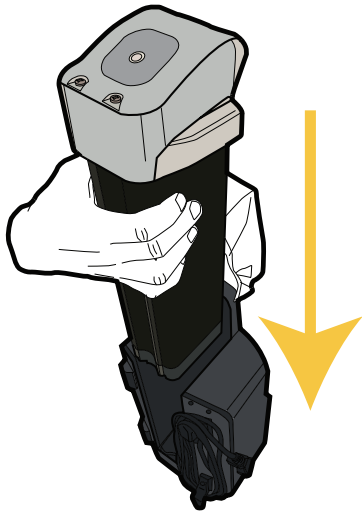

**Table 1** - Minimum gauge for extension cords

Ampere rating		Volts	Total length of cord			
			7.62 m (25 ft)	15.24 m (50 ft)	30.48 m (100 ft)	45.72 m (150 ft)
More than, A	Not more than, A	120 V	mm <sup>2</sup> (AWG)			
0	6	—	0.82 (18)	1.3 (16)	1.3 (16)	2.1 (14)
6	10	—	0.82 (18)	1.3 (16)	2.1 (14)	3.3 (12)
10	12	—	0.82 (18)	1.3 (16)	2.1 (14)	3.3 (12)

## 2.1 BATTERY HOUSING AND CHARGING

Inspect battery housing, plug, cord, splash cover, and helmet (if applicable) for damage including cracks, separation, dents, holes, missing pieces, or fraying. Do not charge or use if damaged.



Lower battery down into the battery housing.

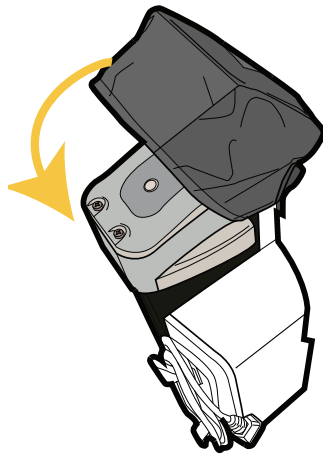

Place and secure the Splash Cover over the battery top.

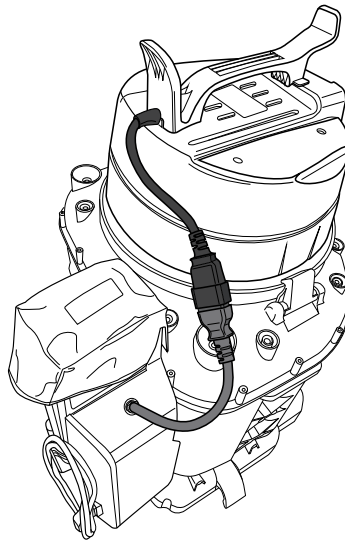

Connect the plug from the battery housing into the vacuum motor plug.

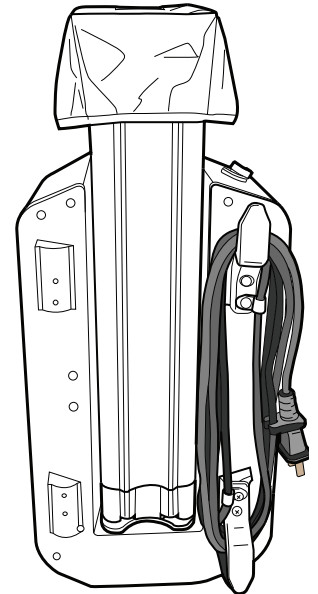

To charge the battery, keep the battery in the battery housing. Locate the cord wrapped around the cleats connected to the battery housing, plug into an outlet to begin charging.

**BATTERY POWERED UNITS EQUIPPED WITH PROTECTIVE HELMET WILL NOT BE ABLE TO ACCESS LOCKING MECHANISM.**

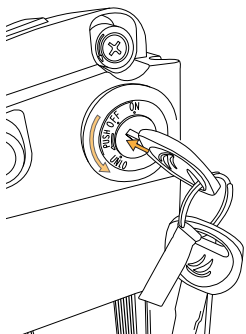

Push key IN and rotate counter clockwise to Unlock.

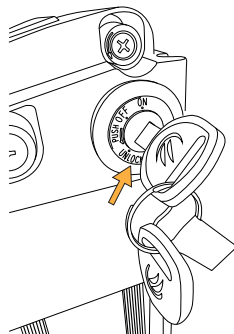

Key needs to be in the unlock position to remove.

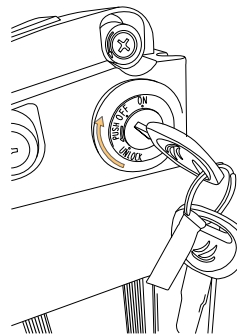

Once in place, turn key clockwise to OFF to lock in place.

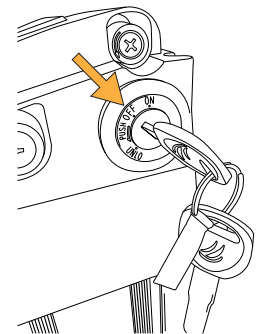

## 2.2 TOOL ARRANGEMENT

\*Corded Only\*  
Power Cord  
(EXT15)

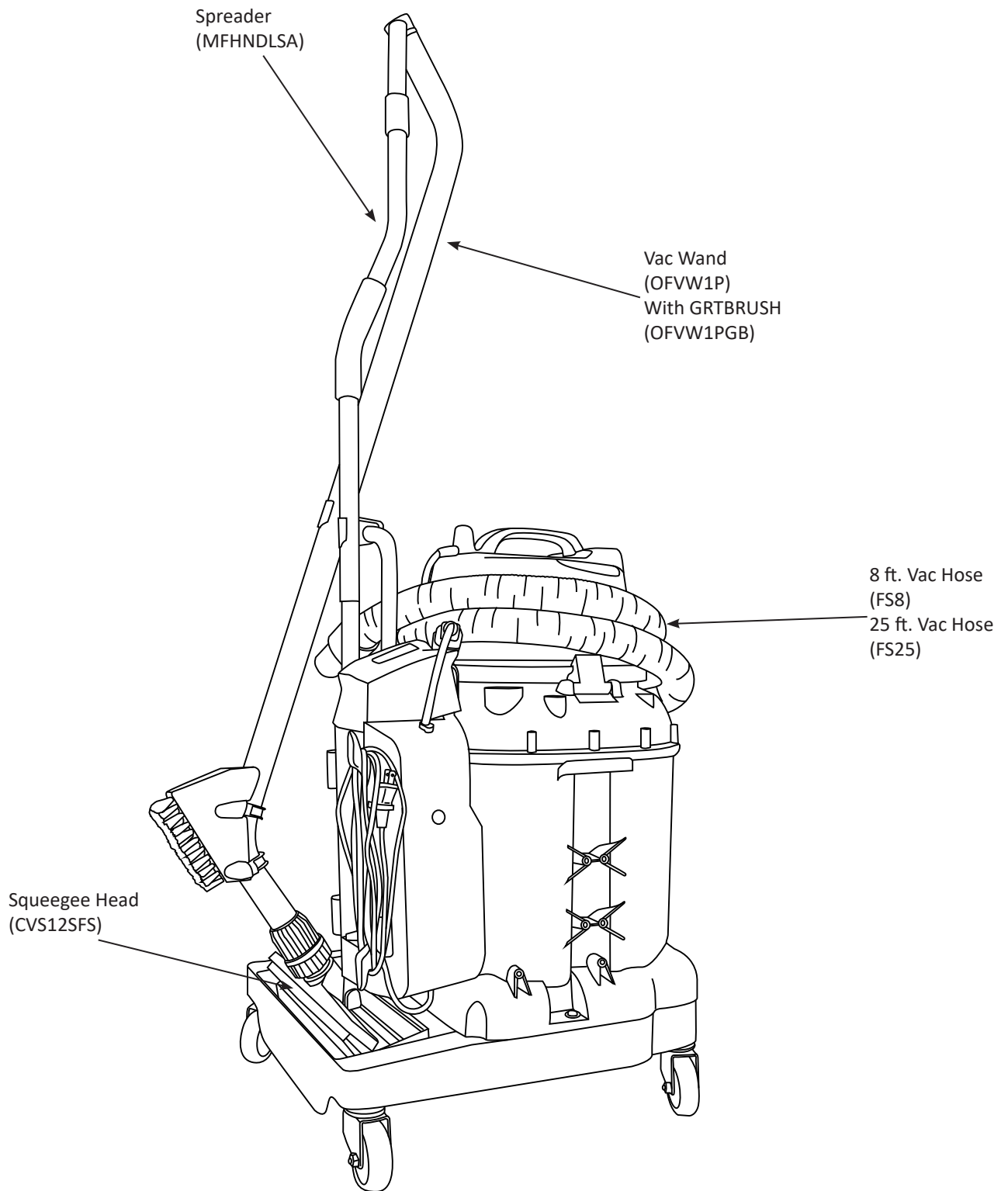

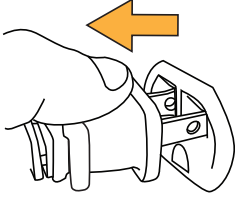
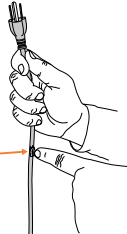
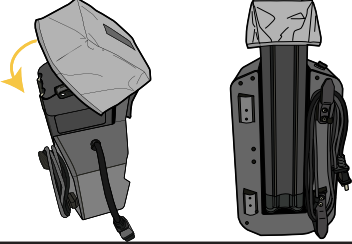
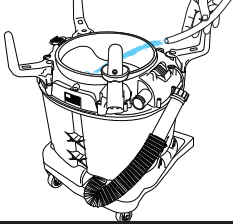
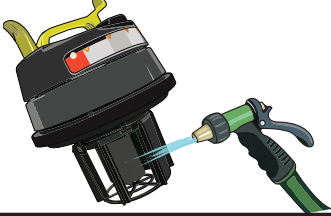
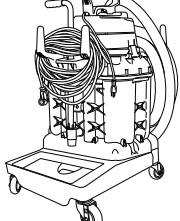

## 2.3 PREPARATION FOR USE

<p>1. Unplug the charger from the battery, if applicable.</p>	
<p>2. Inspect battery, housing, plug, cord, splash cover, and helmet (if applicable) for damage, including cracks, separation, dents, holes, missing pieces, and fraying cord or wires. Do not use a damaged unit or a unit with a damaged battery. Check all hoses and spray lines for damage prior to use. If damage is found, do not continue until proper repairs are completed.</p>	
<p>3. <b>Always install splash cover over the battery.</b> The battery splash cover protects the battery from airborne chemicals and liquids. The splash cover should be installed over the battery per the diagram above while the unit is being used and during charging. This will provide additional protection for the battery from exposure to airborne substances and splashes water and cleaning solutions.</p>	
<p>4. Lift the top of the vac head off the unit to reveal the unit's water tank. Fill unit's water tank with clean, cold water. Avoid getting water on the unit, and ensure that the splash guard is in place.</p>	
<p>5. Clean and spray the Float Cage located inside the Vacuum Head. Ensure Float Cage is in place. Clean Float Cage regularly <b>⚠ CAUTION</b> Do not use if Float Cage is not in place.</p>	
<p>6. Check unit for all tools and supplies needed to complete task. See <i>Tool Arrangement</i> in Section 2.2 of this Manual.</p>	

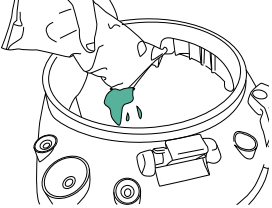

## 2.3 PREPARATION FOR USE (CONTINUED)

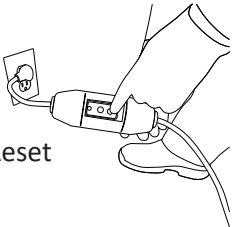
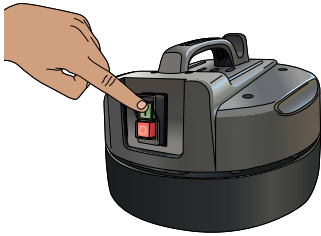
<p>7. If using chemical, locate the vac head and remove to reveal inside of water tank. Insert Kaivac chemical pouch into the water tank. If using a bulk chemical, use only Kaivac approved chemicals and ensure proper dilution of chemical is used.</p>	
<p>8. If using a cleaning product that foams, use a foam inhibitor to cut excess. Pour 2 capfuls of inhibitor in the Vac Hose with Vac running to coat inside of hose.</p>	
<p>9. If corded, plug in unit and test GFCI (Ground Fault Circuit Interrupter) to ensure it is working properly. You are now ready.</p>	
<p>10. If using a battery-powered unit, ensure the battery is fully charged. Power on the Vac Head.</p>	



## 2.4 FILLING THE UNIT

Before filling the unit, be sure the splash cover is in place and secure.

**CAUTION** Before filling the unit's water tank with water or solution, ensure the spigot is in the "OFF" position.

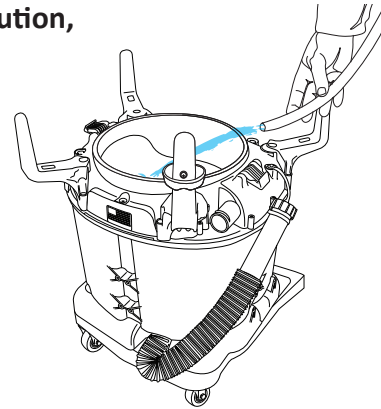
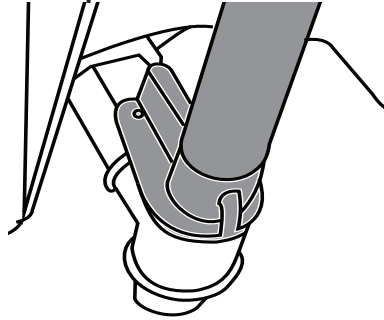

### NOTICE

Fill the tank with water and recommended amount of **Kaivac approved Chemicals**. Follow the proper dilution instructions on bottles or dispenser. For accuracy and convenience, use Kaivac proportioned chemical packets. **Recommendation: IF A CHEMICAL IS BEING USED, USE ONLY KAIVAC APPROVED CHEMICALS AT THE RECOMMENDED DILUTION.**

## 2.5 EMPTYING VACUUM TANK

If the Vacuum Motor shuts off before the job is complete, the Vacuum Tank may be full and need to be emptied. Lift the Vacuum Motor to check liquid level inside the Vacuum Tank. If unit is full or your job is complete, follow the instructions below to empty Tank into appropriate sink/drain.

To begin the dumping process, you must first press down on the Cap and turn counter-clockwise. Once cap is removed, lower Dump Hose into appropriate sink/drain.

**CAUTION** To prevent an accidental spill or overflow from the Dump Hose, be careful to keep hose end upright until it is over sink/drain.

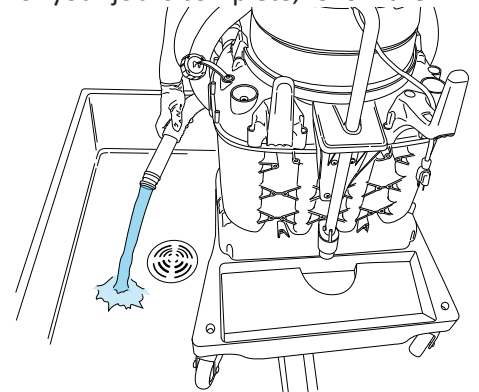
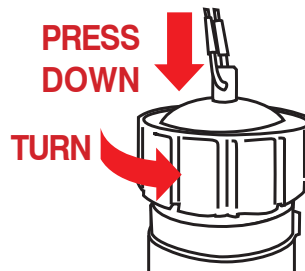

Before starting each new cleaning process, remove Filter Bag, dump any debris out, spray clean, and then replace back into the Filter Bag Frame.

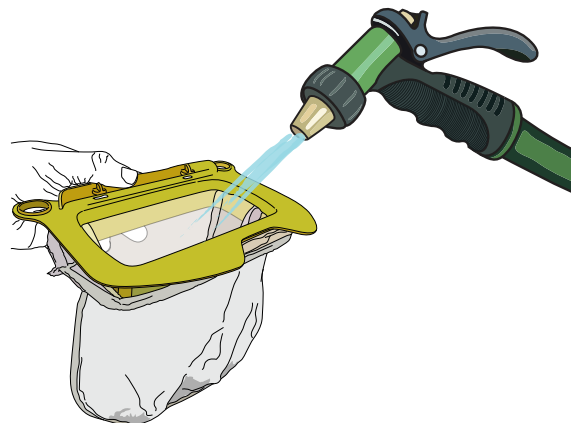
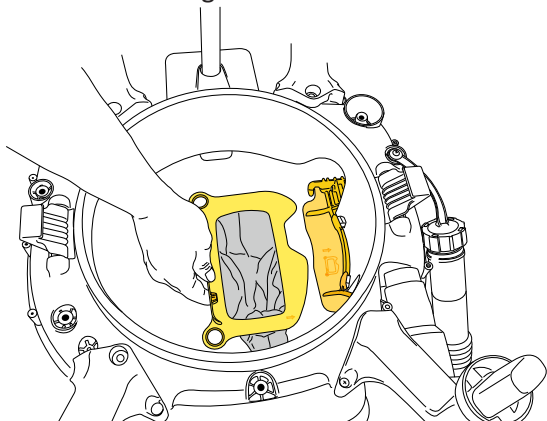

## 2.6 UNIVAC<sup>®</sup> OPERATION

Cleaning with the OmniFlex Univac in Dispense-and-Vac mode is better, safer and faster than cleaning with a mop. You apply fresh cleaning solution to the floor, spread and lightly brush into grout lines, then vacuum away all soils and liquids.

After the unit's water tank has been filled with the appropriate amount of water/chemical, turn the Spigot handle counter clockwise to MAX position.

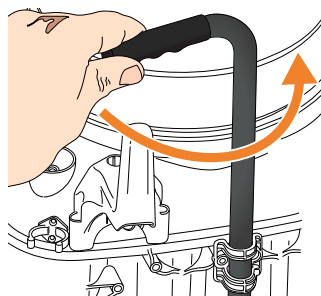

Beginning at the rear of the area, begin dispensing solution, moving towards the front of the area. Park unit so that it blocks entry to area.

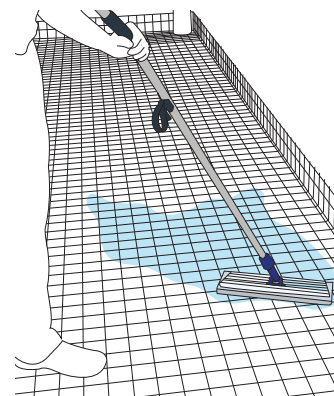
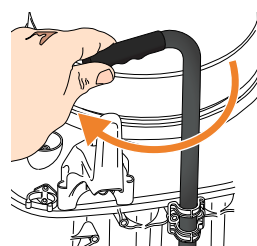
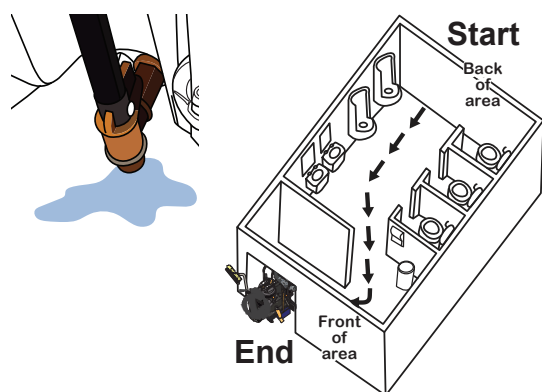

Turn Spigot clockwise to the OFF position. Use Spreader Tool in back-and-forth motion to cover floor with cleaning solution. *\*Agitate Spreader Tool over troubled or extra soiled areas to get a deeper clean\**

Turn Vacuum Motor to ON. Attach Vacuum Wand to Vacuum Hose (if not already connected). The yellow portion of the hose will connect to the wand. The black portion will be connected to the tank.

**Slap & Tap:** Once Vacuuming is complete, keep motor running. Slap Vacuum Wand on floor 3-4 times to dislodge debris from squeegee head. Then, invert Wand and Tap 4-5 times to dislodge any fluids or substance from Wand.

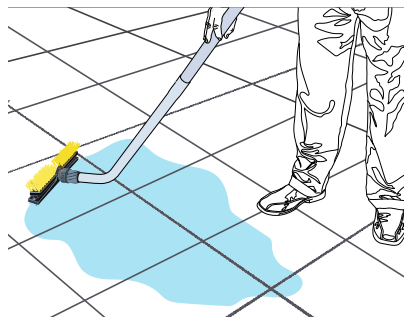
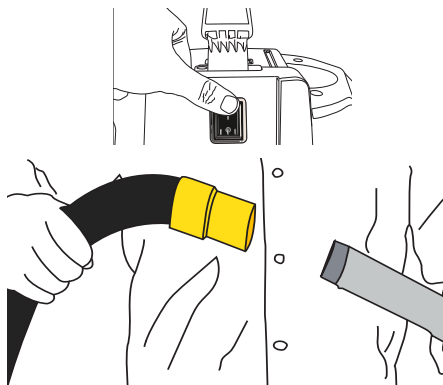

Vacuum floor surface diagonally to grout lines, reaching under shelves, seating etc.

Then Turn OFF Motor.

## 3.1 MACHINE & BATTERY MAINTENANCE

**CAUTION** Always unplug machine before servicing unit or inspecting.

ITEM	PROCEDURE
Floor Squeegee	<ul style="list-style-type: none"> <li>Check condition of squeegee blades and wheels on the floor tool.</li> <li>Rough floor surfaces will cause the blades and wheels to wear out more quickly. Replace as necessary.</li> </ul>
Spray Gun	<ul style="list-style-type: none"> <li>Check spray pattern. If spray pattern will not pinpoint, clean orifice by removing it with an Allen wrench and flushing. Replace if needed.</li> <li>If nozzle becomes difficult to move from high to low pressure, lubricate nozzle with lithium grease.</li> </ul>
Pressure Hose	<ul style="list-style-type: none"> <li>Wipe clean after each use.</li> <li>Check for cuts or frays in the hose jacket, particularly at the end of the fittings. Replace hose if cuts are found.</li> </ul>
Water Tank	<ul style="list-style-type: none"> <li>Check condition of filter in water tank. Clean as needed.</li> <li>Empty the water tank to prevent mildew and bacteria growth. Empty tank by dipping the vacuum hose into the water tank and transferring the water to the vacuum tank.</li> </ul>
Vacuum Tank	<ul style="list-style-type: none"> <li>Empty and flush vacuum tank.</li> <li>Clean and disinfect.</li> <li>Check the float shutoff screen to be sure it is not blocked or dirty. A plugged filter screen restricts airflow and results in reduced suction.</li> </ul>
Leaks	<ul style="list-style-type: none"> <li>Be alert for leaks around hoses, fittings, spray wand, tanks or elsewhere.</li> <li>Discontinue use until leaks are repaired.</li> </ul>
Electrical System	<ul style="list-style-type: none"> <li>The ground fault circuit interrupter (GFCI) must be tested before each use.</li> <li>Electrical cord must be inspected for tears or cuts in the insulation.</li> </ul>
Vacuum Wand	<ul style="list-style-type: none"> <li>Use a wire or coarse brush with acid cleaner to remove residue from threads on the coupling and coupling nut. Apply grease when done.</li> </ul>
HEPA Filter	<ul style="list-style-type: none"> <li>Replace every 3-6 months depending on use.</li> </ul>
Float Cage	<ul style="list-style-type: none"> <li>Ensure cage is sprayed and cleaned daily to remove debris.</li> </ul>
Battery Maintenance	<ul style="list-style-type: none"> <li>Inspect battery, plugs, cords, splash cover, and chemical-resistant plastic protective helmet (if included) before charging and after charging.</li> <li>Always use splash cover.</li> <li>Always keep helmet affixed to top of battery if your battery is so equipped.</li> <li>To view the battery, temporarily move the splash cover. Replace the splash cover after inspection. Do not use unit if battery shows any damage, including cracks, dents, holes, fraying, or missing pieces.</li> <li>Once your battery run time is less than 55% (50 minutes for non-quick change and 30 minutes for quick change batteries), contact Kaivac to replace your battery. Regardless of run time, replace your battery after 4 years. Consult <a href="http://Kaivac.com">Kaivac.com</a> for information on recycling your old battery.</li> <li>The battery splash cover must remain in place. Without the battery splash cover, the battery housing may become damaged which may cause the battery to malfunction, which can result in a fire, explosion, personal injury, and/or property damage.</li> <li><b>Never use a battery that has been damaged in any way.</b> Damaged batteries may exhibit unpredictable behavior resulting in fire, explosion, or risk of personal injury and property damage. <b>Never use or charge a damaged battery pack.</b></li> <li><b>Never dispose of the battery in the trash. It is important that your old, damaged battery is disposed of as instructed by Kaivac Customer Care/Technical Support at 1-800-287-1136.</b></li> <li>DO NOT charge batteries outdoors.</li> <li>DO NOT attempt to repair, service or modify the batteries or charger. Contact Kaivac Technical Support with any issues.</li> <li>DO NOT use a battery that has been damaged in any way. DO NOT incinerate the battery even if it is non-working or severely damaged. The battery can explode in a fire.</li> <li>DO NOT expose a battery or unit to fire or excessive temperature. Exposure to fire or temperature above 265°F (130°C) may cause explosion.</li> <li>DO NOT use or store the NTC System or battery in refrigerated areas, in environments when the battery is in direct contact with liquids, or near flammable or combustible materials.</li> <li>DO NOT charge or store battery for extended time (1 month or more) in temperatures below 40°F (4°C).</li> <li>DO NOT use a battery or appliance that is damaged or modified. Damaged or modified batteries may exhibit unpredictable behavior resulting in fire, explosion or risk of injury.</li> <li>If unit is smoking or sparking, move outside to a fire-safe location immediately. If possible, disengage battery from unit, notify management, and call Kaivac Technical Support at 800-287-1136, Ext. 2</li> </ul>
Splash Cover	<ul style="list-style-type: none"> <li>Inspect splash cover for damage.</li> <li>Clean and dry the splash cover.</li> <li>Be sure the splash cover is secure.</li> </ul>

# 3.2 DC BATTERY QC POWER PACK ELECTRICAL DIAGRAM

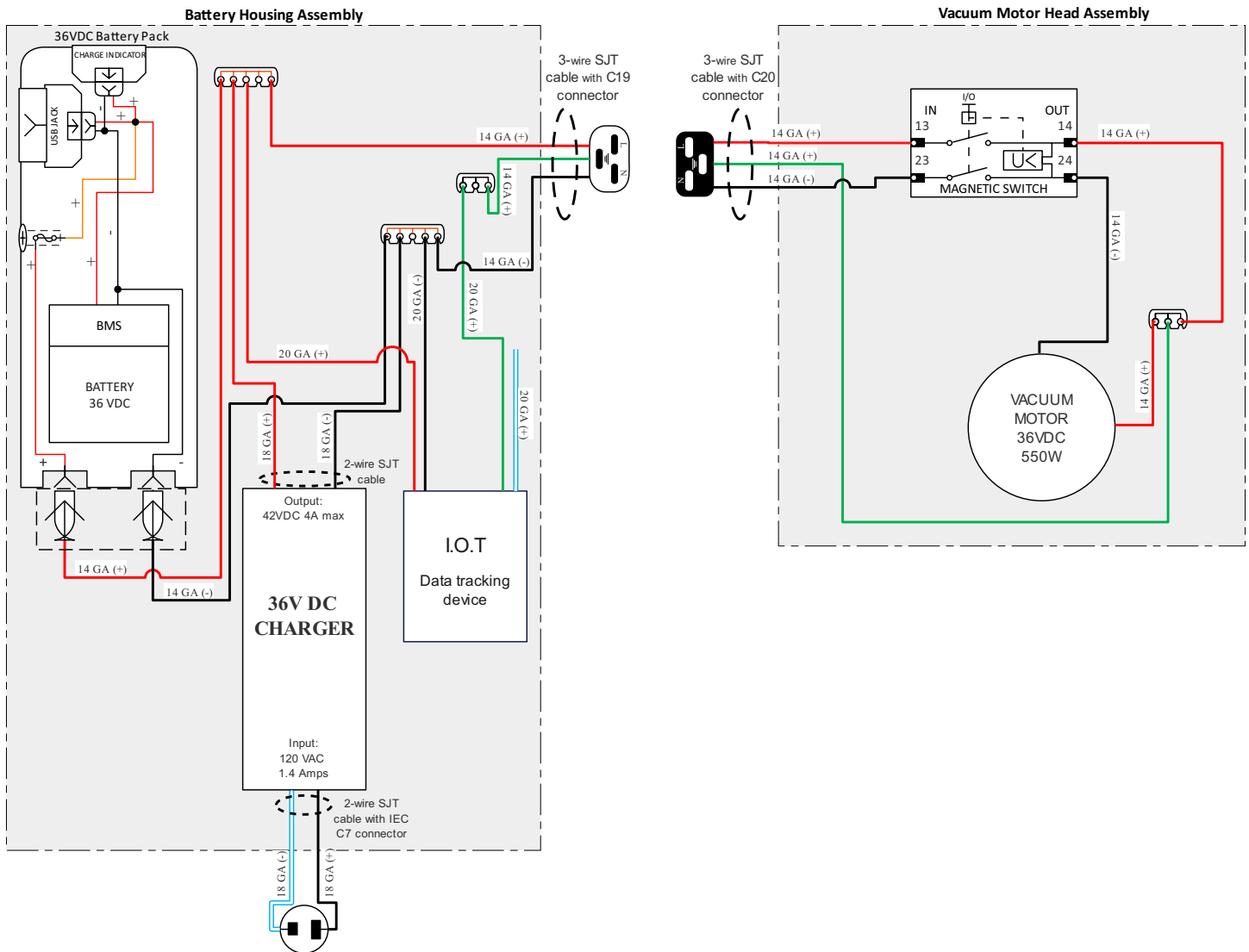

# 3.3 AC CORDED ELECTRICAL DIAGRAM

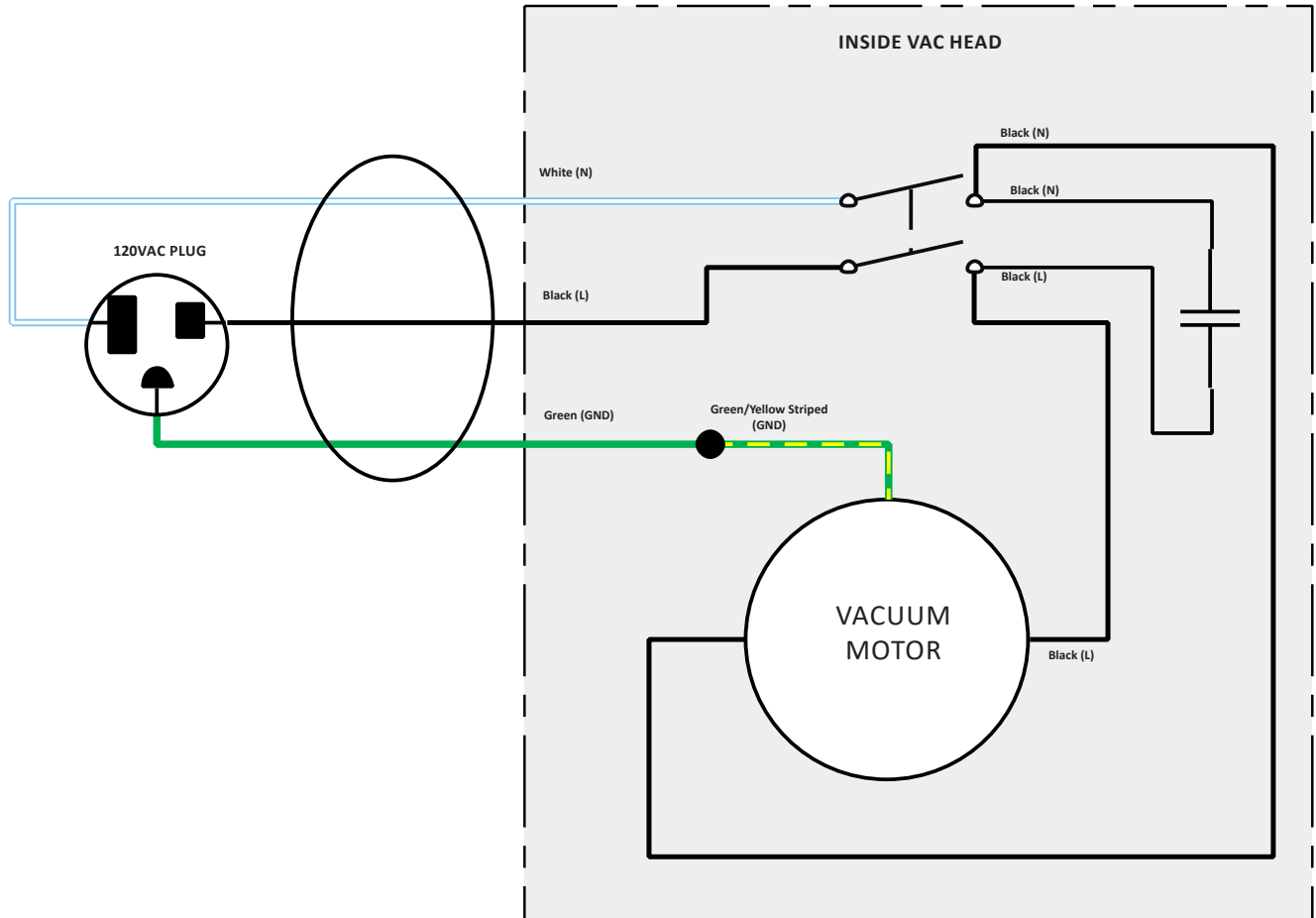

## 4.1 TROUBLESHOOTING TIPS

### • POOR VACUUM PICKUP

1. Check Squeegee Blades. If blades are worn or damaged, replace Squeegee Head.
2. Clean float cage.
3. Check for leaks in the Vacuum Hose or Gasket.
4. Check for clogged Vacuum Hose.
5. Check to see if float ball was tripped.

### • VACUUM SHUTS OFF PREMATURELY

1. Check Float Cage; clean if dirty.
2. Cleaning Chemicals may be producing too much foam. Use correct Chemicals.

### • OTHER ISSUES? CONTACT TECHNICAL SUPPORT

#### PHONE:

United States and Canada: 1-800-287-1136

International: 1-513-887-4600

#### EMAIL:

info@kaivac.com

For Technical Support Contact Form go to: <https://www.kaivac.com/contactus.php> and choose Technical Support tab.

## 4.2 REPLACEMENT (MONTHLY)

The following tasks should be performed monthly to keep your unit operating at peak performance.

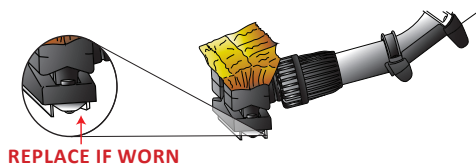

Check for worn squeegee blades. Worn blades cause streaking and loss of vacuum suction.

Unscrew cuff at end of Vac Wand, remove old head and replace with new every 6-8 weeks for optimal performance.

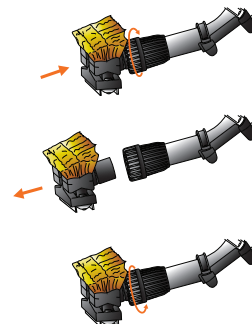

**IMPORTANT:** If cuff is removed, ensure Brass Ring stays in place.

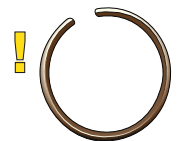

# 4.3 TROUBLESHOOTING



**CAUTION**  
RISK OF ELECTRIC SHOCK  
AND FIRE

**CAUTION** Always unplug unit before inspecting or servicing the unit, including accessing electrical component

AREA	PROBLEM	POSSIBLE CAUSE	
<b>CAUTION</b> Electrical	No Power to pump or vac motor	Machine not plugged in	Plug machine in
		Switch not "on"	Check switches for "on"
		GFCI tripped	Test and reset GFCI
		Building circuit overloaded	Check and reset circuit
		Switch wires loose	Disconnect power and check for loose wire
		Connections loose	Disconnect power and check for loose wire under panel
	Electrical burning smell <b>WARNING</b> TURN UNIT OFF IMMEDIATELY.	Vac motor brushes worn	Remove vac motor and repair
		Vac motor hung up	Release pressure on hose and jog vac switch, or replace
		Pump motor hung up	Release pressure on hose and jog pump switch, or replace
Vacuum System	No/Weak vacuum	Vac tank full	Empty vac tank
		Squeegee blades or wheels worn	Replace wheels or blades and check periodically
		Float shutoff screen dirty	Spray off float screen to clean
		Float ball stuck	Tap float and release/clean
		Damaged hose	Cut and repair/replace
		Dump hose plug missing	Contact dealer and replace
		Access lid not right	Tighten lid hand tight
		Vacuum hose plugged	Flush hose to remove debris
		Too much liquid in vac hose	Allow air in when vacuuming
		Vac hose still wrapped	Unwrap vac hose fully
		Exhaust plugged	Clean exhaust port and HEPA filter
		Leak in vac tank	If repairable, clean and dry affected area and seal with silicone
	HEPA filter clogged	Remove HEPA filter and clean	
	Moisture from exhaust	Vac tank full	Dump vac tank
		Float shutoff missing	Replace
Excessive foam in vac tank		Use defoamer	
Blow Dry System	No air flow	Hose disconnected	Reconnect hose
	Moisture from exhaust	Water in blow hose	Dry blow line
	Suction, not blow action	Vacuum hose connected to vac tank	Reconnect to vac motor exhaust hose

## 4.3 TROUBLESHOOTING (CONTINUED)



Always unplug unit before inspecting or servicing the unit, including accessing electrical component

AREA	PROBLEM	POSSIBLE CAUSE	SOLUTION
High Pressure System	No water from pump or low pressure	Out of water	Fill water tank
		Gun nozzle plugged	Remove orifice with Allen wrench and clean
		Air in pump (vapor lock)	Use power prime technique
		Gun orifice missing	Replace orifice
		Water tank filter plugged	Clean tank and filter
		In-line bowl filter plugged	Remove filter cover and clean
		Bowl filter lid loose	Gently tighten bowl cover
		Pressure hose damaged	Repair or replace
		Quick disconnect leaking	Tighten or replace
		Injector plugged	Remove safety cap from chemical and blow small amounts of compressed air into line
		Pulse hose damaged	Repair or replace
		Regulator failed	Replace
		Hose kinked	Unkink and check for damage
	Seals in pump need replaced	Remove and replace seals	
	Bad fan pattern or pinpoint pattern on gun	Debris in nozzle	Remove orifice with Allen wrench and clean
Orifice damaged		Remove and replace	
Chemical Injection System	No chemical flow	Out of chemical	Refill chemical
		Safety cap not secure	Check safety cap/tighten
		Chemical valve "off"	Check on/off valve
		Safety cap plugged	Replace cap
		Spray gun in wrong mode	Make sure gun nozzle is pulled out away from gun chemical mode
		Metering tip plugged	Check metering tip for clog
		Injector plugged	Remove safety cap from chemical and blow small amounts of compressed air into line
		Air entering system	Check for air entering system around chemical lines or injector
		Injector installed backwards	If fluttering or pulsing sound can be heard while spraying or when machine is running, it is possible that your injector is in backwards. Remove; reinstall.
		Kink in chemical line	Replace chemical line



## 4.3 TROUBLESHOOTING (CONTINUED)

**CAUTION** Always unplug unit before inspecting or servicing the unit, including accessing electrical component

AREA	PROBLEM	POSSIBLE CAUSE	SOLUTION
Chemical Injection System continued	Not enough chemical	Metering tip plugged	Remove and clean
		Wrong metering tip	Check and replace per chart
	Chemical line blows off safety cap	Debris in injector	Remove safety cap from chemical and blow small amounts of compressed air into line
		Water back flows into chemical bottle	Bad seat on injector check valve
Dump System	Dump hose will not empty tank	Bad safety cap	Replace safety cap
		Dump hose cap not removed	Remove cap
	Dump hose leaks	Clog in bottom of tank	Tip dump contents, remove debris
		Hose cut	If leak is less than 4" from tank side, cut and reattach, or replace
Wheels and Casters	Wheels will not roll; rubbing	Clamp loose	Tighten hose clamp
		Dump cap missing	Replace cap
		Flat tires	Inflate tires to 30 p.s.i.
		Debris wrapped around axle	Check for debris on axle
		Bearings tight	Grease bearings
Squeegee Head	Floor streaks	Wheels too loose on axle	Remove wheel, add washers to take up slack
		Bearings falling out	Replace bearing assembly
	Squeegee head does not easily rotate when installed on wand	Worn blades or wheels	Replace wheels and/or blades
		Brass ring on wand not in groove	Loosen coupling nut and re-position head on groove
	Head will not stay on wand	Coupling nut too tight	Loosen 1/2 turn
		Coupling nut cracked	Replace
Premature blade wear	Brass ring worn	Replace	
Battery	Sucks to the floor too tightly	Squeegee wheels worn	Check wheels for wear/replace
		Sparks/Burning/Fire/Smoke	Check wheels for wear/replace
	 <b>WARNING</b> STOP USE IMMEDIATELY	Damage to battery or charger	Disconnect battery from charger, if possible. Unplug charger, if possible. Stop use immediately.

# 5.1 VACUUM TANK ASSEMBLY PARTS DIAGRAM

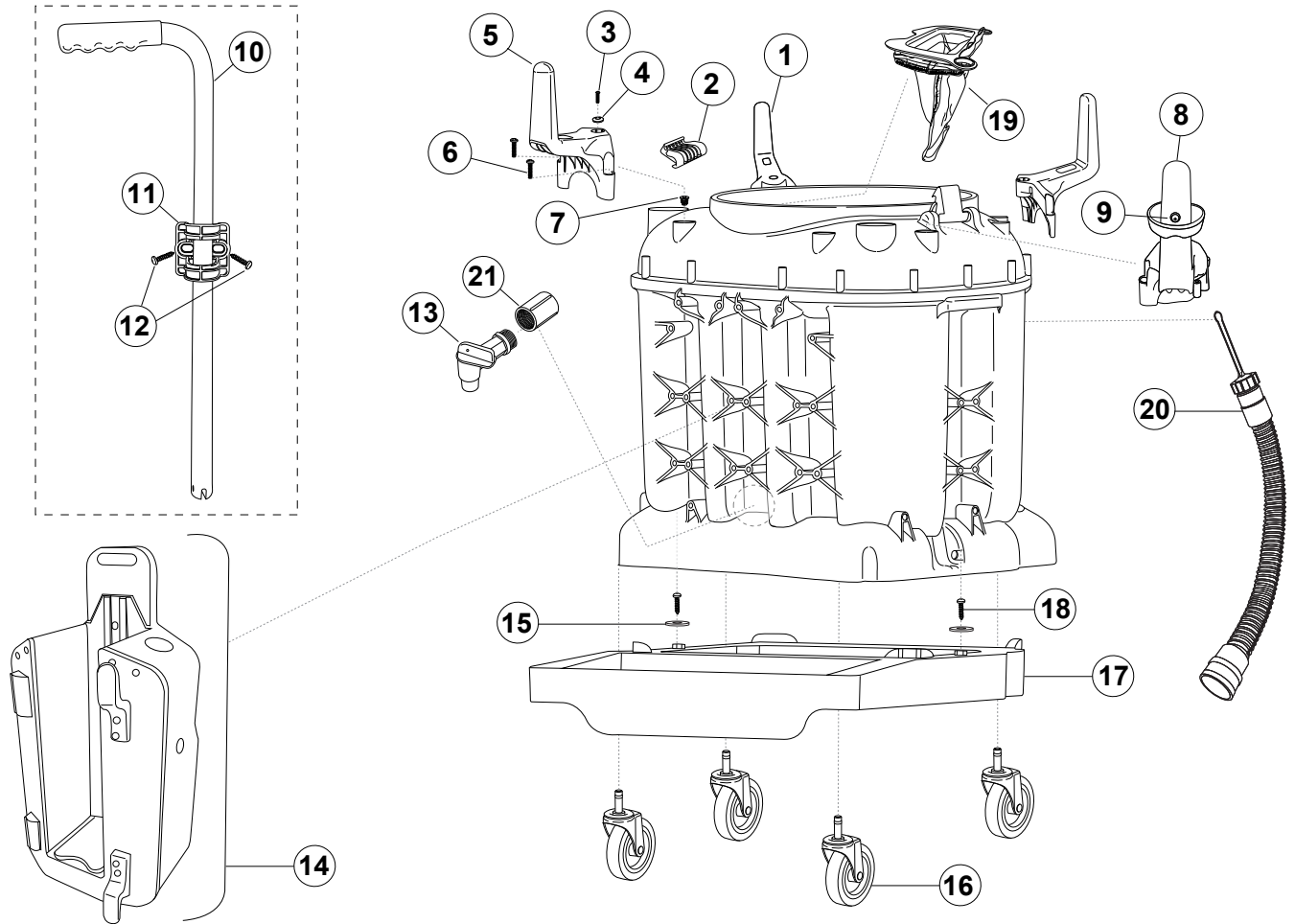

[P/N: VTOF11, VTOF34, OVTAU2]

#	PART NO.	PART DESCRIPTION
1	OSTOB2	OMNIFLEX MULTI PURPOSE POST - HOSE PORT
2	CLASP1Y	OMNIFLEX CLASP UPPER YELLOW
3	CSS209	8-32 X 3/4 ROUND HEAD MACHINE SCREW (AC ONLY)
4	CSS306	WASHER BONDED NEOPRENE 1/4ID X 5/8OD (AC ONLY)
5	OSTOB	OMNIFLEX MULTI PURPOSE POST
6	CSS322	10 X 3/4 PHL PAN HI-LO (AC ONLY)
7	CSS211	8/32 IN. INSERT FOR MOLDS (AC ONLY)
8	VHDTY	VAC HOSE DRIP TRAY
9	CSS208	8 X 1/2 SS TRUSS SCREW
10	COHA00	POWDER COATED HANDLE

\* Battery units only

11	OVTSHB	OMNIFLEX VAC TANK SPIGOT HANDLE BRACKET
12	CSS329	1/4-10 X 1 PLASTITE ZINC PAN TORX 30
13	KMB22A	OMNIFLEX SPIGOT BLACK PLASTIC
14A*	EABT09	QC INTERFACE W/ INTEGRATED CHARGER & IOT
14B*	EABT16	QC INTERFACE W/ INTEGRATED CHARGER & IOT - INTL
14C*	EABT04	QC INTERFACE W/ INTEGRATED CHARGER
15	CSS44	1/4 FLAT WASHER
16	OFCSTR	OMNIFLEX 3 INCH CASTER
17	GP0022	UNIVAC CHASIS FRAME
18	CSS364	1/4-10 X 1 1/4 IN PLASTITE PAN TORX
19	OBAGY	MESH BAG (YELLOW)
20	HVDH00	OMNIFLEX DUMPHOSE

## 5.2 VACUUM HEAD ASSEMBLY PARTS DIAGRAM

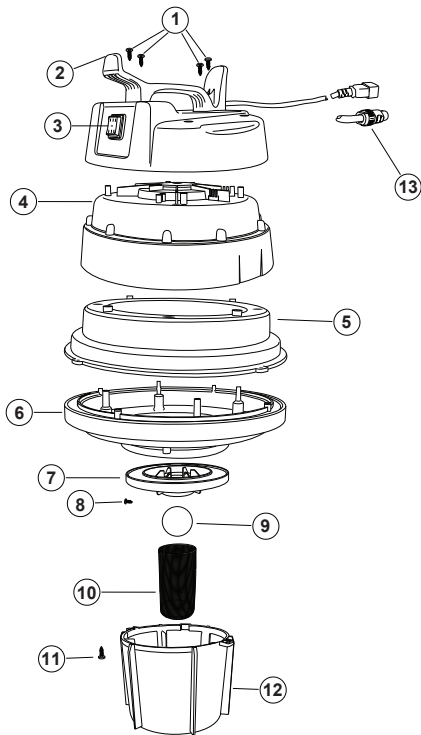

[P/N: VM3D00, VM3D02, VM3D05, VMAWDZ2, VMAWDZ240VI, VM-UL-AWDZT2]

#	PART NO.	PART DESCRIPTION
1	CSS17A	8 SST SCREW 3/4 IN
2	OVMHANLP	OMNIFLEX VAC MOTOR HANDLE BLACK LOW
3	ZD10TC	OMNI VAC MOTOR TOP COVER
4	ZD10MC	OMNI VAC MOTOR MIDDLE COVER
5	ZD10MR	OMNI VAC MOTOR MIDDLE RING
5	ZD10MR36	OMNI VAC MOTOR MIDDLE RING — 36V
6	ZD10BC	OMNI VAC MOTOR BOTTOM COVER
7	GA0002	FLOAT INTERFACE ASSEMBLY
8	CSS318	5/6" SS PHILLIPS FOR ZD 10/FCINT
9	CVS26	OMNIFLEX FLOAT BALL
10	ZD10	STAINLESS STEEL FLOAT CAGE
11	CSS313	SCREW #7 PANHEAD PHIL SS 1/2 IN
12	ZD10B	OMNI VAC MOTOR BASKET
13A	HEPC02	POWER CORD 22.5 IN - C20 MALE
13B	CSS315DC2	ELEC. MALE PLUG 36VDC 20A
13C	CSS315AU	AUS PLUG IP44
13D	CSS315UK	UK PLUG IP44
13E	OP3TPR	3 PRONG MALE PLUG TWIST-LOCK

## 5.3 QUICK CHANGE POWER PACK ASSEMBLY PARTS DIAGRAM

[P/N: EABT09, EABT04, EABT16]

#	PART NO.	PART DESCRIPTION
1	HEPC01	C19 CABLE
2	CSS359	10 X 3/4 FLAT HEAD FORMING SCREW
3	BINTPLUG	BATTERY BASE PLUG
4	GP0008	BATTERY CHARGER HOUSING
5	CES12	3/8 CONDUIT CLAMP
6	HETR01	IOT UNIT
7	GP0009	BATTERY CHARGER HOUSING LID
8	GP0010	CORD WRAP/CLEAT
9	CSS322	10 X 3/4 PHL PAN HI-LO
10	HWM010	CABLE CLAMP 3/16 BLACK
11	HWS000	6 X 3/4 THREAD FORMING SCREW TORX
12	CSS359	10 X 3/4 FLAT HEAD FORMING SCREW
13	HEBT00	GUIDE RAIL FOR BATTERY
14	EACG00	36V BATTERY CHARGER
15	HWM004	3/8 ID SHAFT COLLAR
16	HWM005	3/8 ID X 1/2 RUBBER GROMMET
17	HWM006	SNAP GRIP HOSE CLAMP .30 MIN .36 MAX
18	BINTBASE	PLUG BASE
19*	HEPC07	CHARGER EXTENSION

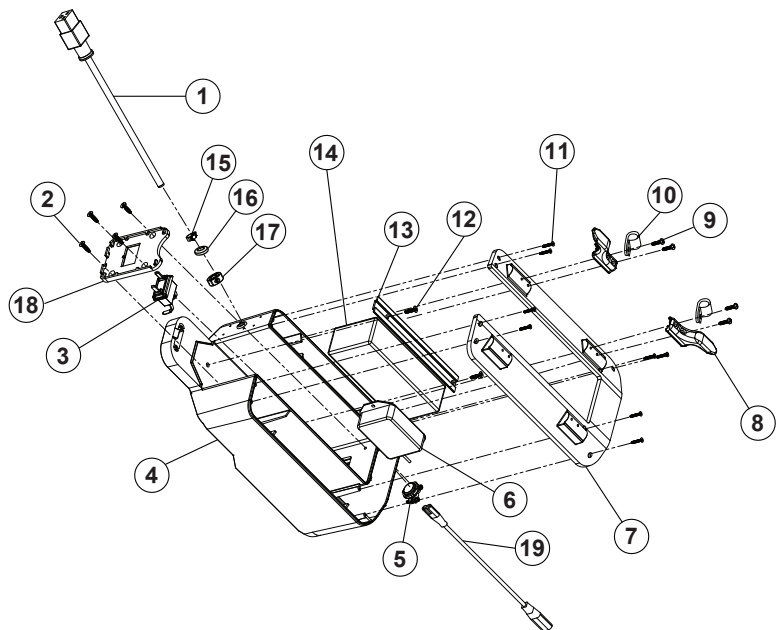

\* International units only

